

Insulated Phone Tip Plugs

- Body is brass with nickel plating. Handle is molded plastic as indicated in table.
- Colors: All of the above plugs are offered in standard -102 red or -103 black. Add color as suffix to part number. Other colors such as white, yellow, green and blue are available by special order.
- Please see pages 6 and 8 for jumpers or test leads using these plugs and page 9 for test prods. Need something similar but different? We have or can make what you need to get the job done.

PART NO.	FIG.	TYPE	HANDLE MATERIAL	AMPS	VOLTS
235	A	RA Solder	ABS	12	1 KV
203	B	Solder	Nylon	12	1 KV
200	C	Solderless	Nylon	12	1 KV

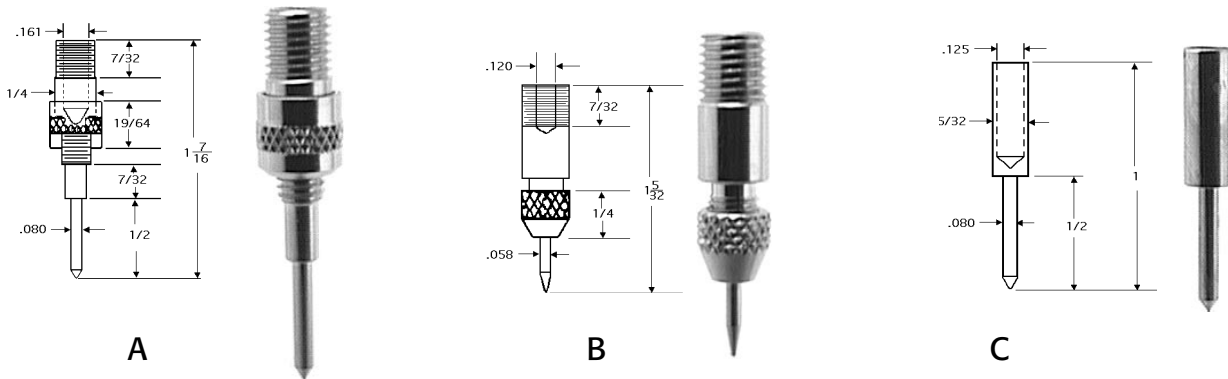

Uninsulated Phone Tip Plugs

- Brass body with nickel plating.
- Needle tips are nickel plated steel.
- Wire leads solder into well in back of plug. On solderless types, wire fits through hole in body, wraps around screw portion and is held with knurled collar.
- Rated at 12 Amps AC for 10°C temperature rise, continuous duty.

PART NO.	FIG.	TYPE	MOUNTING	STYLE
124	A	Solderless	Threaded	Long tip
128	B	Solder	Threaded	Replaceable needle tip
108	C	Solder	Wire Mnt.	Earphone tip, machined